

# **HAND GESTURE CONTROLLED ALL TERRAIN ROBOT USING BLUETOOTH**

# Overview

- Introduction
- Block Diagram
- Hardware Requirements
- Software used
- Applications
- References

# Introduction

- A gesture is a form of non-verbal communication.
- A gesture controlled robot is a kind of robot which can be controlled by your hand gesture.

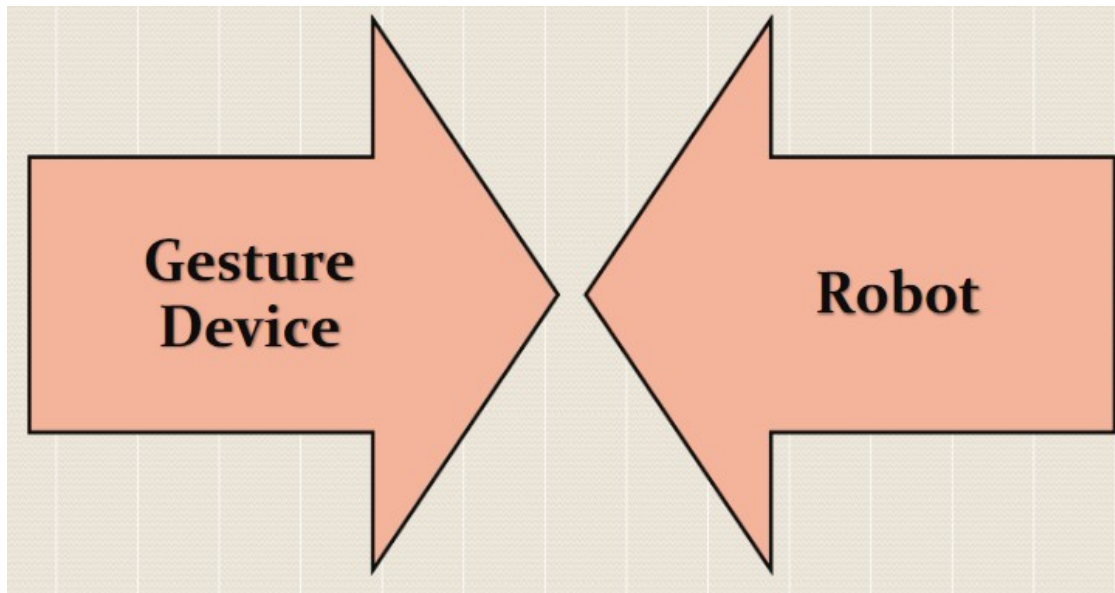

# Block Diagram

Transmitter

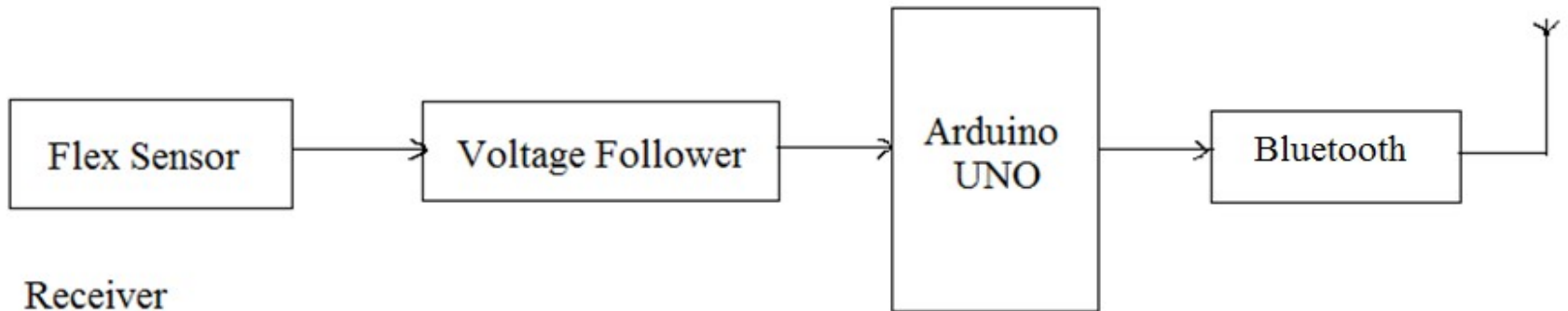

Receiver

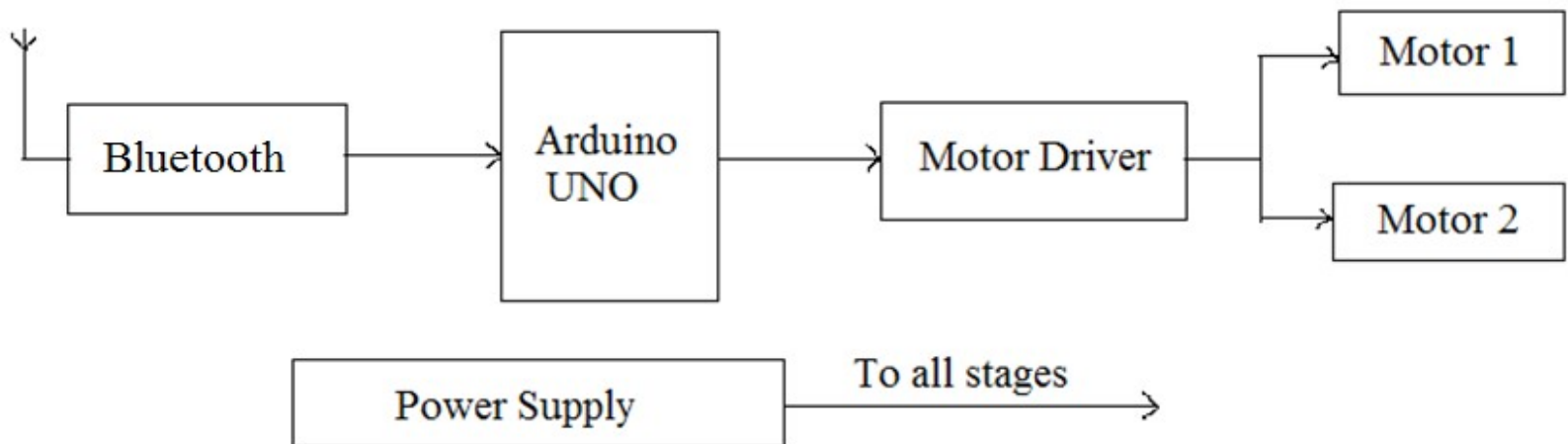

# Hardware requirements

- Arduino Uno
- Bluetooth Module
- Flex Sensor
- Voltage follower
- DC Motor Driver L293D
- DC Motor
- Power Supply

# Arduino UNO

- Microcontroller board based on the ATmega328P.
- 14 digital input/output pins (of which 6 can be used as PWM outputs)
- 6 analog inputs.
- 16 MHz quartz crystal
- A power jack
- Connect it to a computer with a USB cable or power it with a AC-to-DC adapter or battery to get started.

# The board...

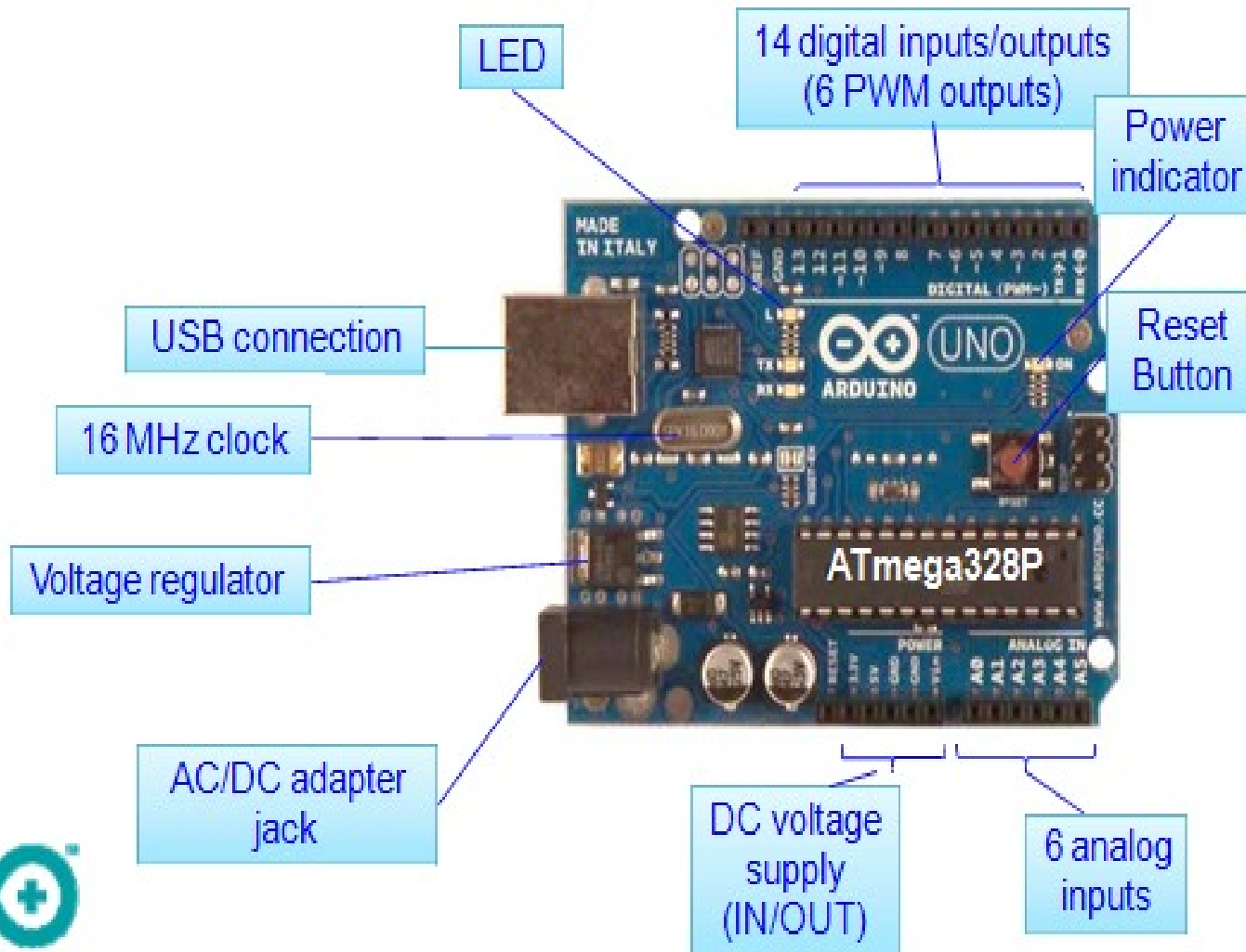

# Bluetooth Module (HC-05)

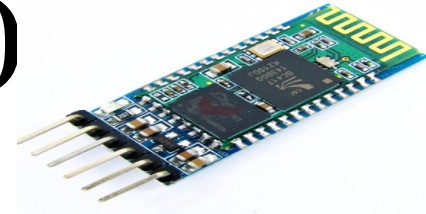

- For the communication between mobile phone and microcontroller Bluetooth module(HC-05) is used
- Low Power 1.8V Operation ,1.8 to 3.6V I/O .
- Serial port Bluetooth module have a Bluetooth 2.0+EDR (enhanced data rate), 3Mbps modulation with complete 2.4GHZ radio transceiver and baseband.
- Using Bluetooth profile and android platform architecture different type of Bluetooth applications can be developed.



# Flex Sensor

- A flex sensor changes its output when it is bent or when force is applied on it.
- The sensor has two output wires.
- The resistance between these two wires varies when the sensor is bent or when subjected to a force.
- They convert the change in bend to resistance.
- The more the bend more the resistance value.

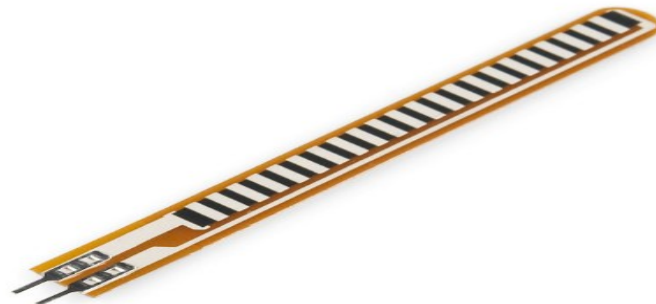

# Voltage Follower

- To avoid loading effect and isolate the output from the signal source, voltage follower or impedance buffer is used with flex sensor

## Basic flex sensor circuit

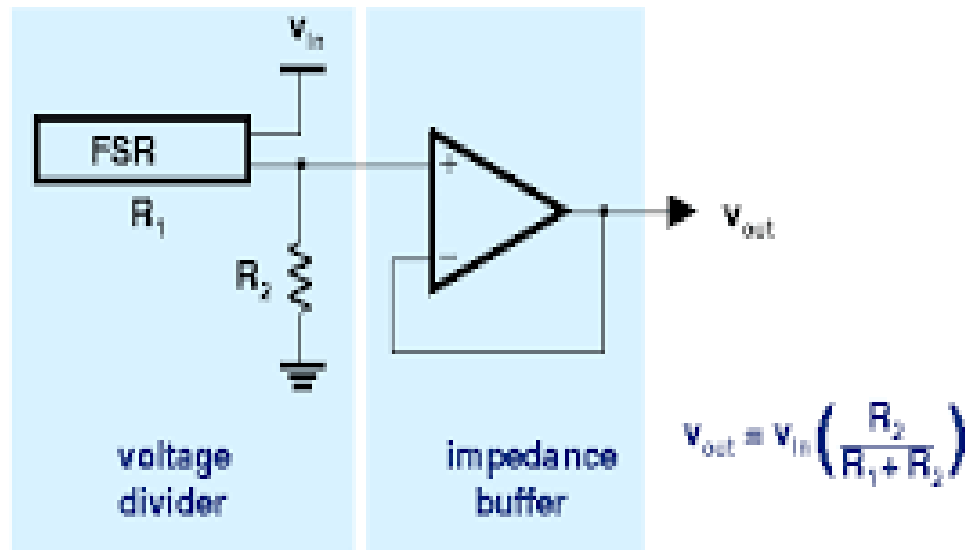

# DC Motor Driver(L293D)

- L293D has quadruple high current half-H drivers.
- Wide Supply-Voltage Range: 4.5 V to 36 V
- High-Noise-Immunity Inputs
- Output Current 600mA Per Channel
- Peak Output Current 1.2A Per Channel.

# Pin Diagram

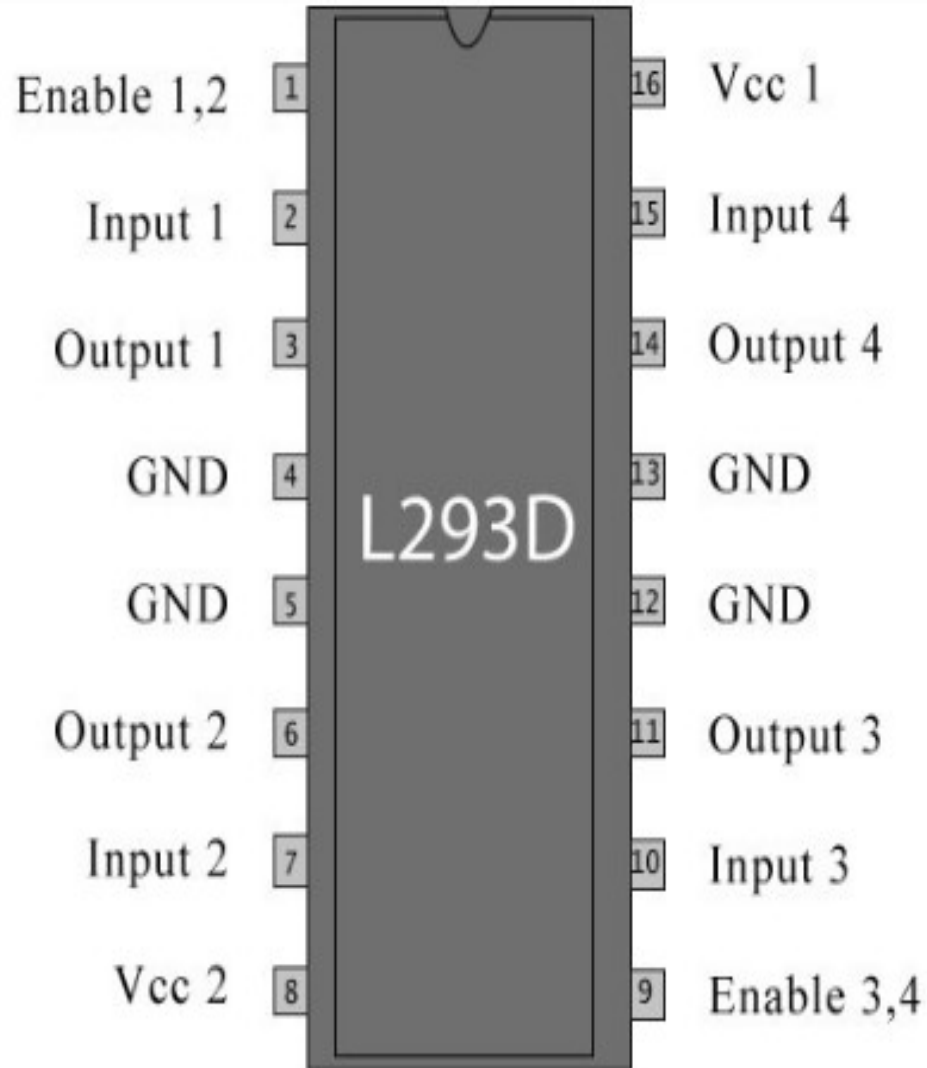

# Circuit Diagram

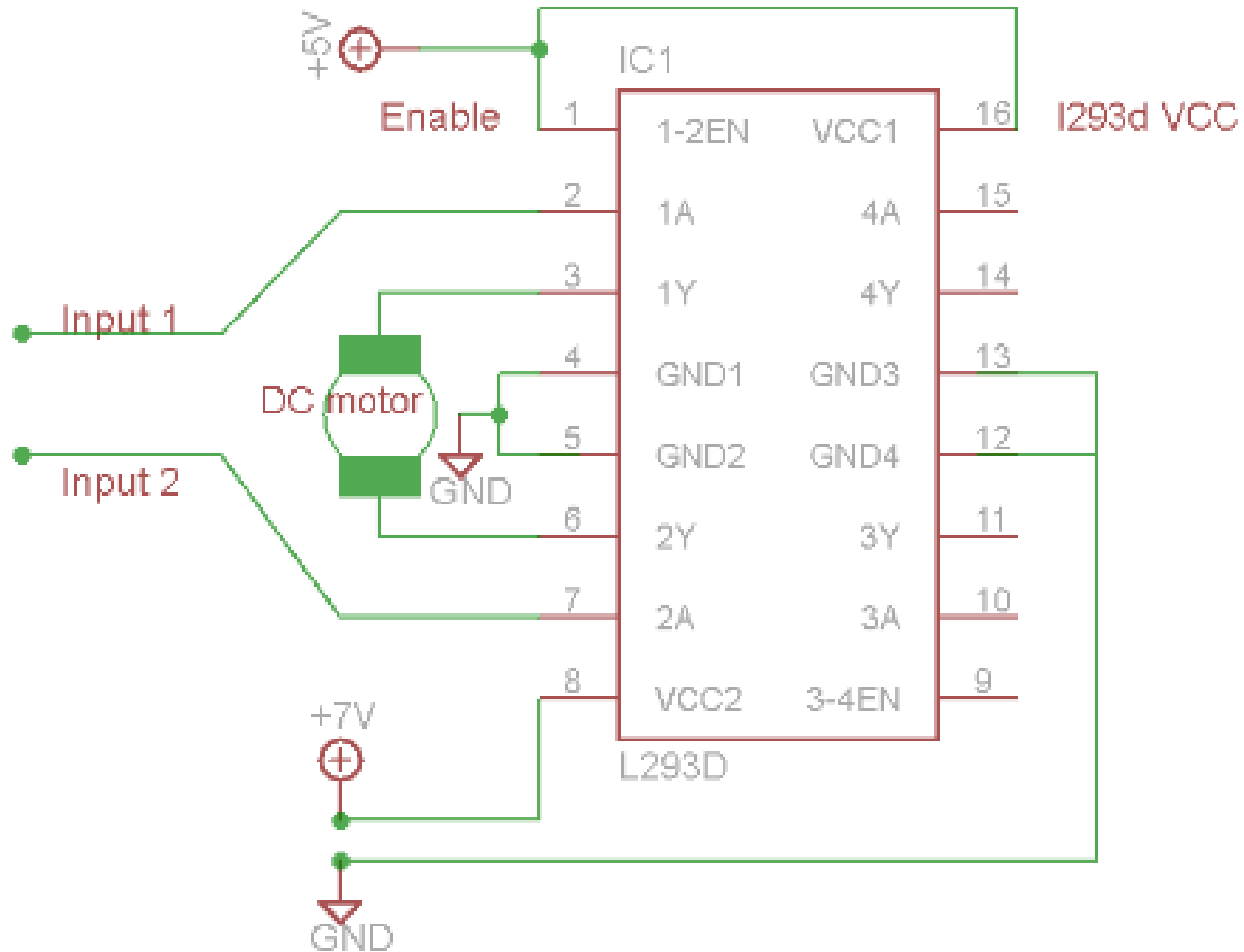

# DC Motor

- 10 to 200RPM 12V DC motors with Gearbox
- 6mm shaft diameter with internal hole
- No-Load Current=60mA(max)
- Load Current=300mA(max)

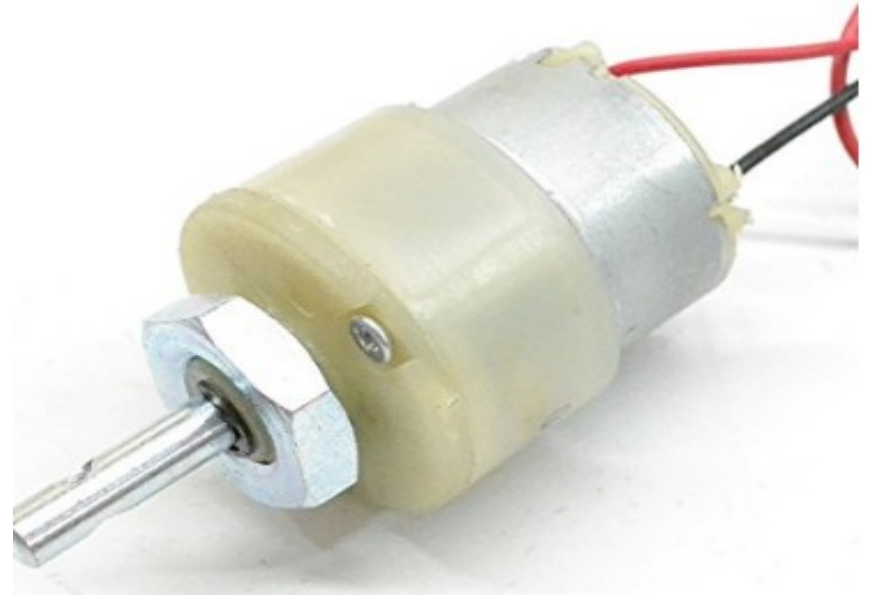

# Power Supply

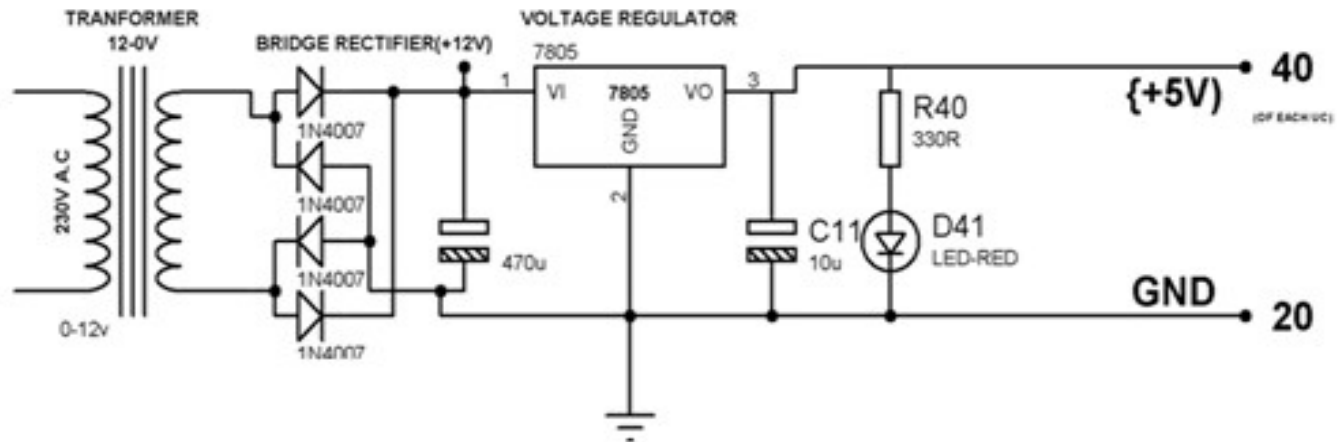
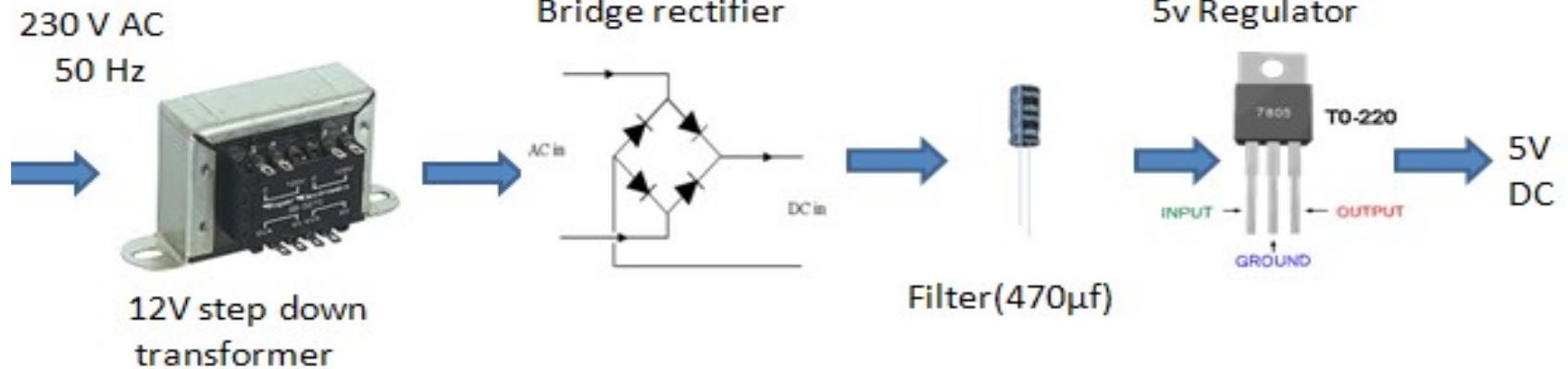

# Software Used..

- Arduino IDE

# Programming Languages Used..

- Embedded C/C++



# Application

- Hospitals
- Industrial robots
- Automobiles



# References

- [www.arduino.org](http://www.arduino.org)
- [www.beyondlogic.org](http://www.beyondlogic.org)
- [www.wikipedia.org](http://www.wikipedia.org)
- [www.elementzonline.com](http://www.elementzonline.com)
- [www.elementztechblog.wordpress.com](http://www.elementztechblog.wordpress.com)

**Questions????**

**THANK YOU**