

## **Abstract**

Dumpster robot is used for industrial automation. It is mainly used to function as a Bull Dozer robot. For dumping it has a bucket which is lifted with the help of a gear box. Thus it can lift heavy loads. ZigBee protocol is used to control the robot wirelessly.

## Block Diagram

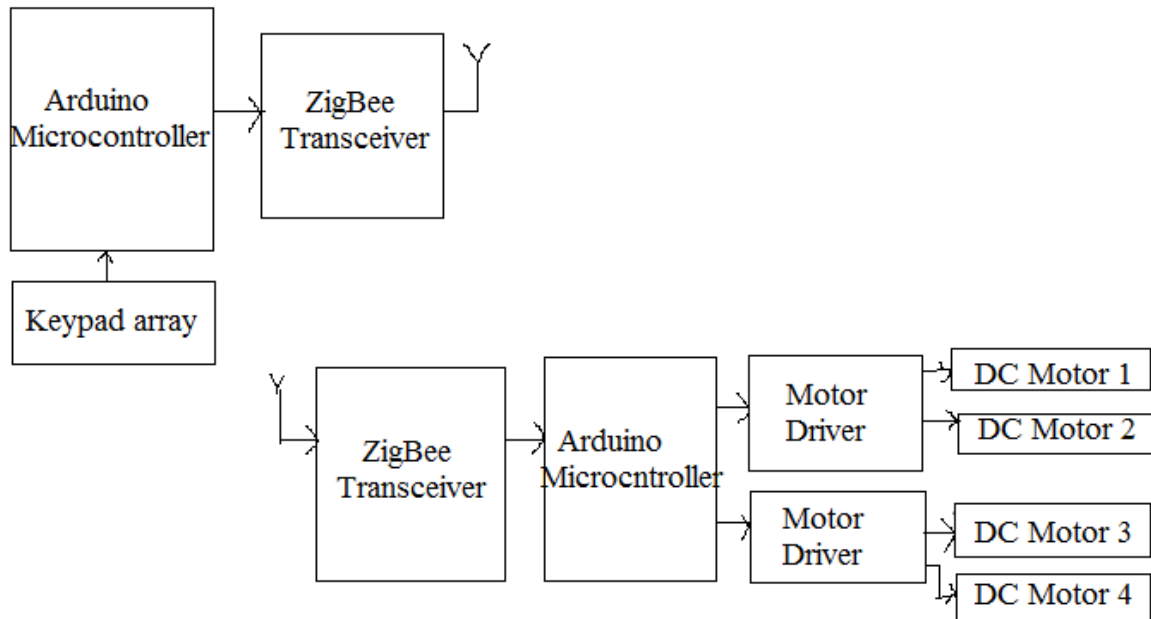

A keypad array of pushbuttons is used to send the control signals to control the robot movements using ZigBee module. At the receiver side the Arduino microcontroller drives the motors used for robotic forward and backward motion and for the robotic movement.